

SSD T/A CREWSAVER SERVICING AND MAINTENANCE BULLETIN No. 48

ISSUED TO: All Service Stations

DATE ISSUED: February 2015

SUBJECT: Replacing old style lights with the new CSL

ISSUED BY: Norman Kitching

EXP DATE: N/A

A requirement has arisen for guidance on the replacement of historic lifejacket lights with the new Crewsaver Surface Light (CSL).

The CSL light is supplied with a fixing clip (a). The clip is placed behind the fabric light retainer (b). The light is secured by pressing the clip onto the back of the light (c). The CSL light is supplied with a fabric light retainer as illustrated below (d). Once the light is fitted to the retainer it can be placed over the mouth inflation tube (e).

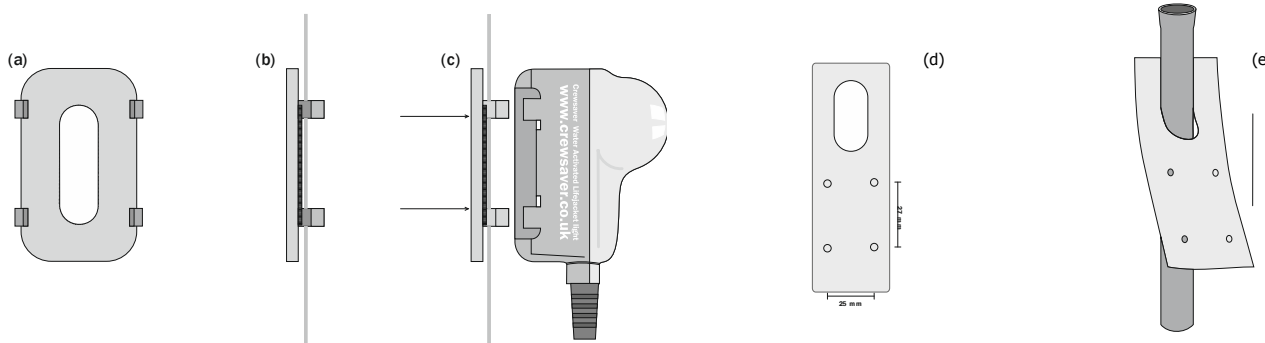

Some lifejackets have a fabric light retainer already sewn into the jacket. The CSL light can be attached to this retainer using the fixing clip shown above. Details regarding the fitting of CSL lights to lifejackets can be found in the relevant Service Manual.

The exception to the above is the old style Seacrewsader 275N (Product code 1042/1043) lifejacket where the light is attached to the 40mm black inflator retainer – see Service Manual. This requires the use of a fabric light retainer as illustrated alongside. These items can be obtained from Crewsaver.

