

Survitec Service & Distribution Ltd (Crewsaver)

Servicing / Technical bulletin number: 064

Issued to: Service Network (All Stations)

Date Issued: Feb 2021

Subject: EXOLOK Cylinder locking system

Issued by: Guy Page (Technical)

Exp date: N/A

Crewsaver are introducing a product improvement to their lifejackets.

A new Cylinder retention system called the "EXOLOK"

The EXOLOK has been designed to help maintain cylinder fastness to the operating head, this works alongside the orange/red Netlon (Mesh) cover which should already be in place.

The EXOLOK will start to be fitted to new lifejackets as of: - March 2021

In some counties there is already a legal requirement to have a cylinder retention system in place and this requirement could apply shortly to your region. (All Lifejacket Manufacturers will need to apply to this)

All Jackets that are operational at this moment in time are recommended to be retro fitted with this system during their next service, this will increase security for seated cylinders and the safety of the person wearing the jacket.

Links to: -

Video explaining the introduction of EXOLOK [Video](#)

User Manual. [Manual](#)

There are two styles to be introduced.

1. An orange version for all UML operating head types.
2. A Yellow version for Halkey Roberts Manual operating heads only.

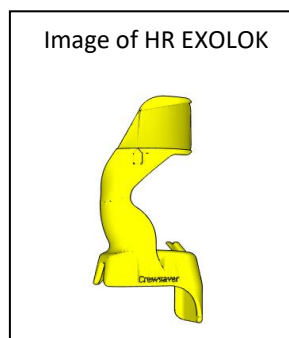
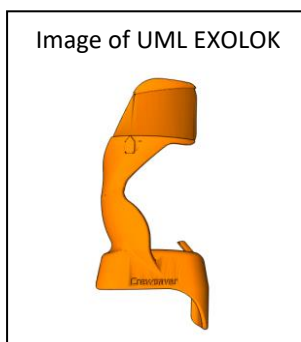

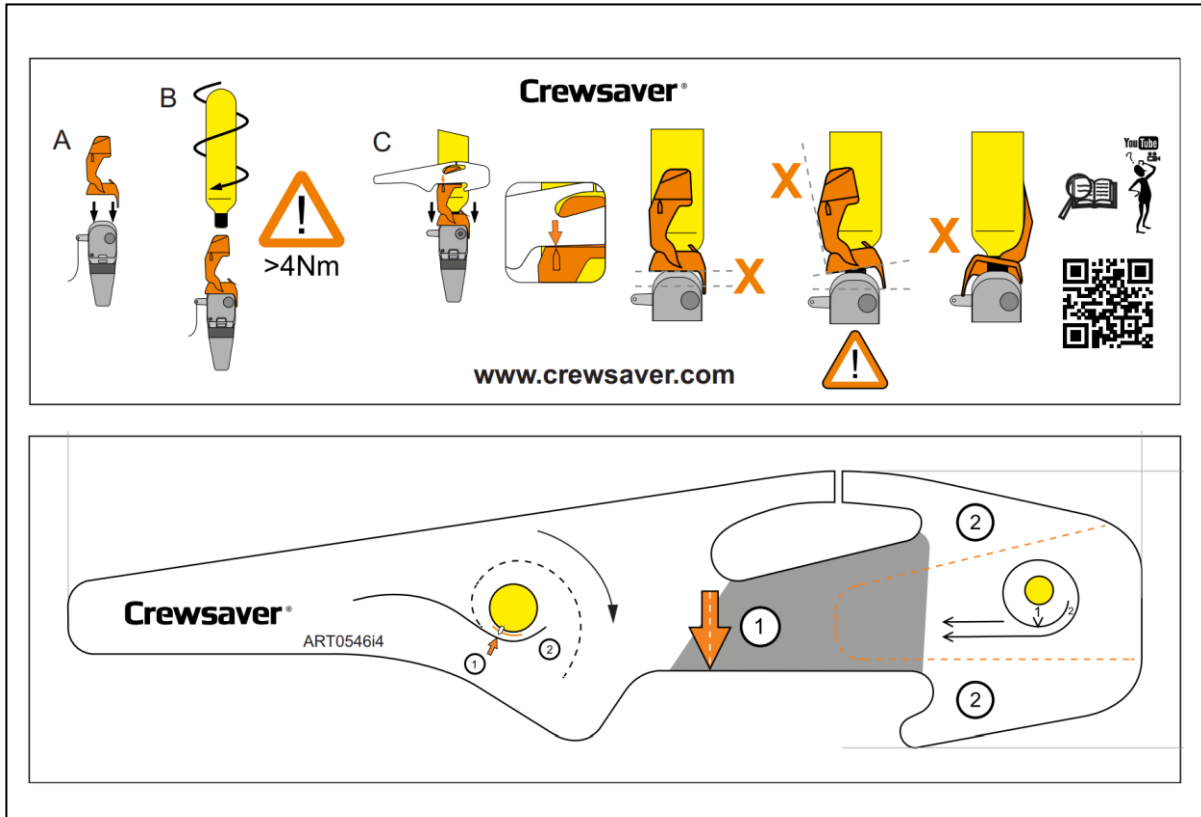

Fitting.

Fitting the EXOLOK to current life jacket

1. Correctly open the jacket (Ref to service or user manual).
2. Remove the orange/red Netlon (Mesh) cylinder cover from the cylinder. (Image 1.A)
3. Remove the CO₂ Cylinder, hold the operating head firmly and turn the cylinder Anti-clockwise. (Image 1.B)

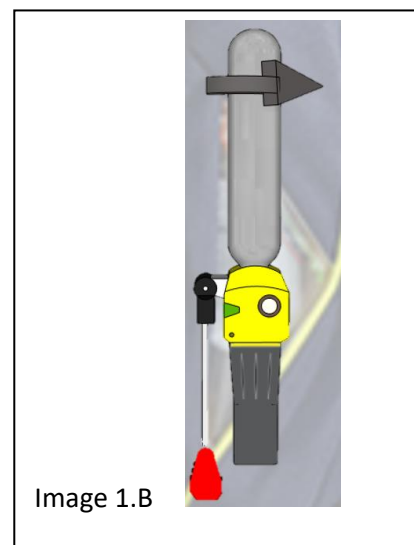

Survitec Service & Distribution Ltd (Crewsaver)

- Please ensure that the Cylinder seal (O-ring or washer) is in good working order and is correctly fitted.
- **Note:** - All O-rings/washers are now changed every service.

- UML Heads

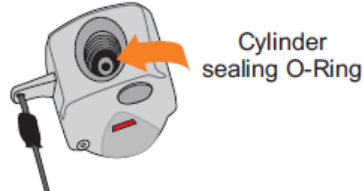

- Halkey Robert head.



- Ensure you have the correct "Crewsaver" cylinder for the life jacket and ensure it is in good working order (Image 1.C).
- Place the EXOLOK mechanism on to the operating head with the Crewsaver logo facing outwards (Image 1.D).

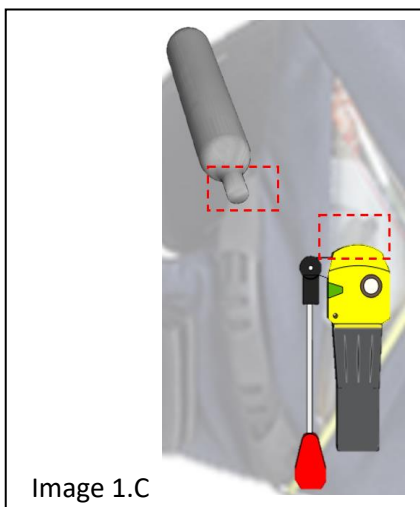

Image 1.C

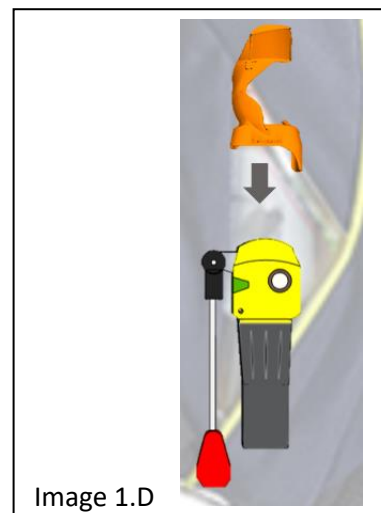
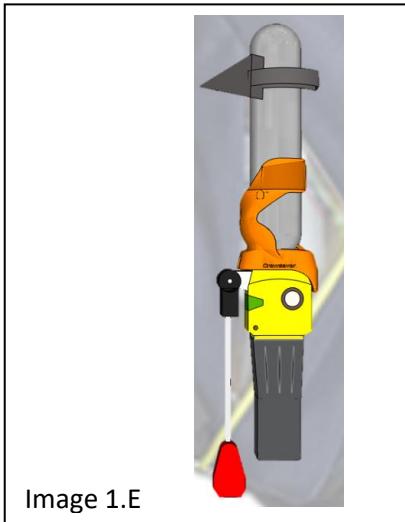

Image 1.D

Survitec Service & Distribution Ltd (Crewsaver)

- Fit cylinder to the operating head by screwing on in a clockwise direction (Image 1.E).
- Ensure the cylinder is screwed right down & fully tightened by hand.
- Check that the cylinder has been tightened to at least 4Nm using a Calibrated torque wrench (Image 1.F).



- If the operating head is fitted with an indicator, ensure this has turned green or the clip is in place (Image 1.G).

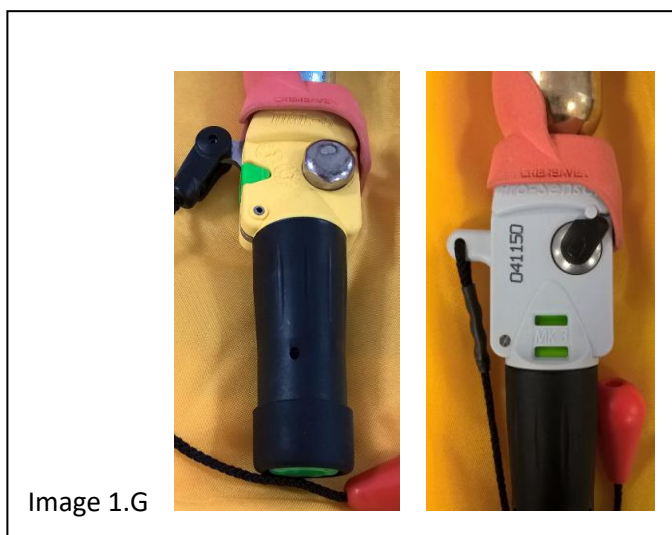

- Add the label to the EXOLOK by lining up both arrows. Whilst attaching the label to the cylinder – the EXOLOK needs to be held securely against the operating head (Image 1.H).

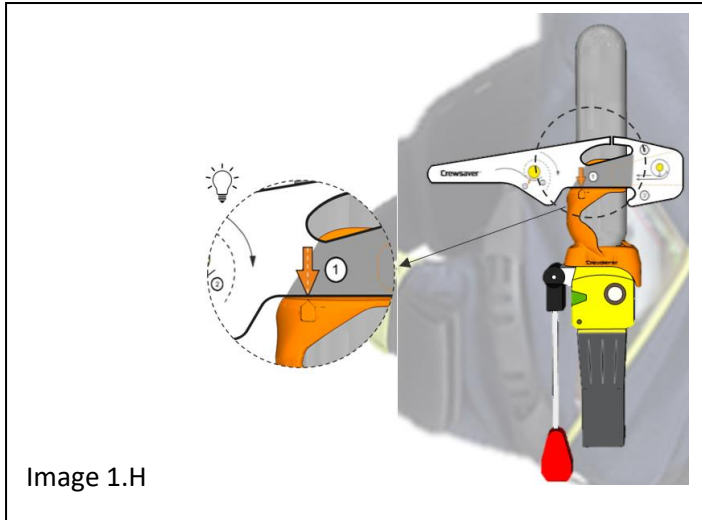

- Wrap the right side of the label around the cylinder (Image 1.I).
- Wrap the left side of the label around the cylinder (Image 1.J).

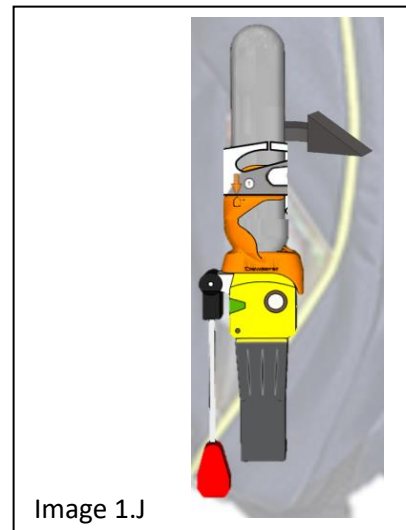
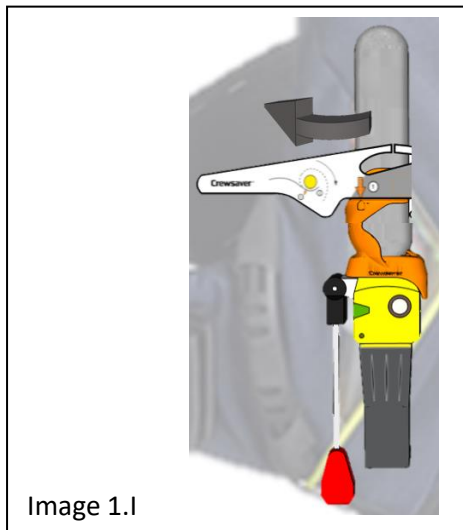

Survitec Service & Distribution Ltd (Crewsaver)

- Slide the Netlon (Mesh) cover back over the cylinder and EXOLOK (Image 1.K).
- The operating system is now ready for use (Image 1.K).

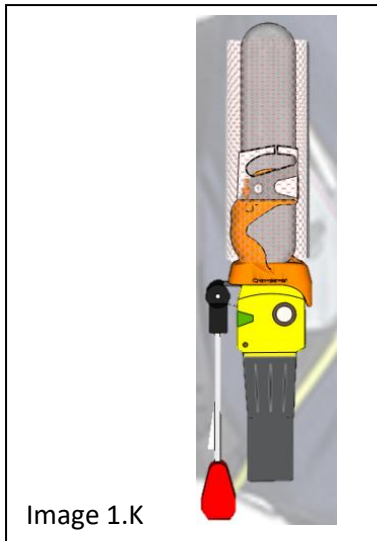

- The jacket can be re-packed
(please ensure you follow the packing instructions as laid down in the service manual).

The following parts must be obtained from Crewsaver:

Part No.	Description
10314	Crewsaver EXOLOK Sticker – (single unit)
10316	Crewsaver EXOLOK unpackaged - (single unit)
10317	Crewsaver EXOLOK HR unpackaged - (single unit)

Tool requirement.

Part No.	Description
10441	Calibrated Torque Wrench 4.0N.m comes with 13mm Socket
900040	Cylinder Tension Belt

Cylinder seals

Part No.	Description
10382	HR Manual head cylinder sealing gasket
11048	UML Head cylinder sealing gasket

Once fitted, only the sticker will need to be replaced during service or if the cylinder needs to be detached from the operating head.

The main unit is re-useable.

Rearm kit with also start to contain a replacement unit. (March 2021)

For costs:- Please email crewsaver.sales@survitecgroup.com

Survitec

Registered Office:
1-5 Beaufort Road, Birkenhead, Merseyside, CH41 1HQ, United Kingdom
Registered in England No. 905173